



CETA FORM®

**Tool Containers
&
Assortments**



2006

Ceta Form Tool Containers & Assortments

Smart service solutions

Due to our investment of sheet steel forming plant in 2004, we are now able to offer not only excellent quality tools but also excellent quality, smartly designed tough tool containers to keep your tools as in their first-day conditions.

In this chapter, you will also find tool assortments in Ceta Form SBS – “smart box system” inlays. Our tool containers combined with SBS inlays offer the ultimate in service organization regardless of the size of the service.



GT-PLUS



GT



GT



Heavy duty oil proof rubber wheels, Ø 125 mm



Low friction telescopic ball bearing slides



Holders for spray cans and paper rolls

A17P

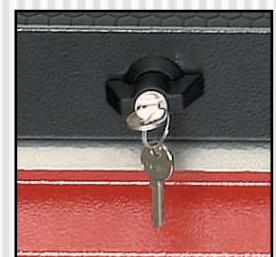

EMKA Central locking mechanism

SBS Inlays

The ultimate in service organization

Our new SBS Inlay program consists of 25 modular tool trays with different contents addressing a variety of needs. Compatible with almost all of the tool containers we offer, the SBS inlays offer the ultimate in service organizations when combined with our tool containers.

Increased efficiency in workshops, missing tools can be identified at a glance.

Finger spaces for easy placement and removal of tools.

Three dimensional cut outs (whereas most companies in the market offer 2D cut outs) which provide the optimal slot for the tools.

Chemically resistant high quality EVA material.

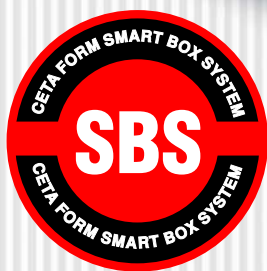

SBS inlays are compatible with almost all of the tool containers we offer.



Possibility to build up almost 3.400.000 different combinations (calculated for a 5 drawer tool cabinet); hundreds of user profiles can be addressed.

Ceta Form Tool Containers & Assortments

Smart service solutions

A01-06 Roller Cabinet GT-PLUS (6 drawers)

- Sturdy and dependable construction, premium quality sheet steel. Elegant and durable electrostatic mat powder coated, scratchproof.
- 6 fully extendible drawers – compatible with SBS inlays.
- Low friction telescopic ball bearing slides ensuring silk smooth operation. Bottom drawer with double slides.
- Foamed rubber mats in drawer bases.
- Central locking mechanism, **EMKA** brand lock in charge. Possibility of key match is 1 in 1.000.000.
- Smart-Lock™ system on every drawer preventing accidental opening while the cabinet is on the move.
- Heavy duty oil proof rubber wheels (125 mm in Ø), two fixed and two swiveling, one with an emergency brake.
- Holders for spray cans and paper rolls.
- Recessed worktop with a high quality mat to ensure a convenient working area.
- May be combined with tool chest A06-04.
- Drawer dimensions:
5 Drawers 525x360x70 mm
1 Drawer 525x380x170 mm
- Weight: 69 kg

New



GT-PLUS

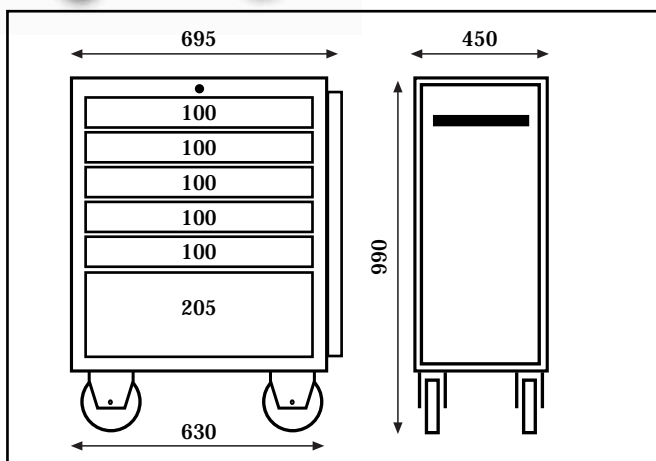

Heavy duty oil proof rubber wheels, Ø 125 mm



Low friction telescopic ball bearing slides



Holders for spray cans and paper rolls

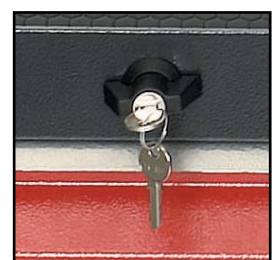

EMKA Central locking mechanism

A02-06 Roller Cabinet GT (6 drawers)

- Sturdy and dependable construction, premium quality sheet steel. Elegant and durable electrostatic mat powder coated, scratchproof.
- 6 fully drawers – compatible with SBS inlays.
- Drawers work on robust ball bearings – removable when needed.
- Foamed rubber mats in drawer bases.
- Central locking mechanism.
- Oil proof rubber wheels (100 mm in Ø), two fixed and two swiveling, one with an emergency brake.
- Recessed worktop with a high quality mat to ensure a convenient working area.
- May be combined with tool chest A06-04.
- Drawer dimensions:
5 Drawers 525x360x70 mm
1 Drawer 525x380x170 mm
- Weight: 60,4 kg

New



GT

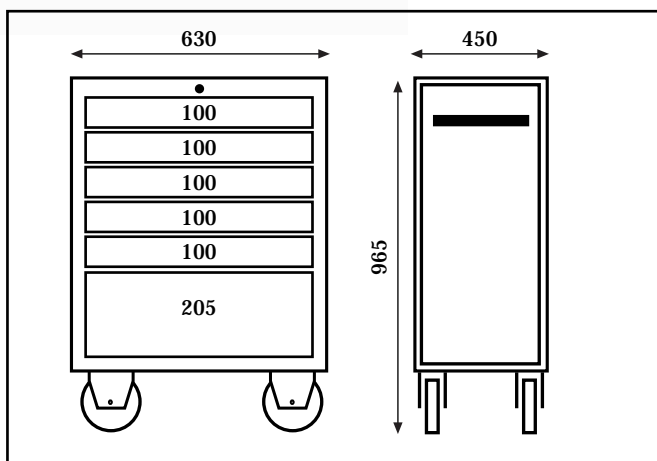

Robust ball bearings



Oil proof rubber wheels, Ø 100 mm



Central locking mechanism

Ceta Form Tool Containers & Assortments

Smart service solutions

A03-06 Mobile Workbench GT (6 drawers)

- Sturdy and dependable construction, premium quality sheet steel. Elegant and durable electrostatic mat powder coated, scratchproof.
- 6 drawers – compatible with SBS inlays.
- Drawers work on robust ball bearings – removable when needed.
- Foamed rubber mats in drawer bases.
- Central locking mechanism.
- Oil proof rubber wheels (125mm in Ø), two fixed and two swiveling, one with an emergency brake.
- Directly accessible tray for bulky items. The middle tray's height is adjustable.
- Recessed worktop with a high quality mat to ensure a convenient working area.
- Drawer dimensions:
5 Drawers 525x360x70 mm
1 Drawer 525x380x170mm
- Weight: 64,2 kg

New



GT

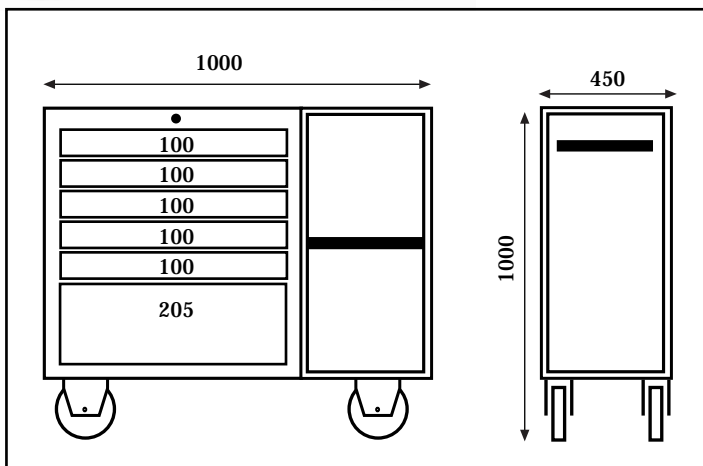

Heavy duty oil proof rubber wheels, Ø 125 mm



Robust ball bearings

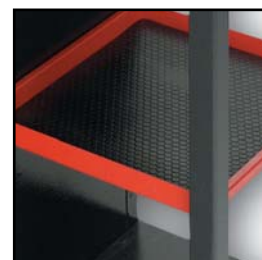

Accessible tray for bulky items



Central locking mechanism